

**Tower Crane
Grue à tour**

Turmdrehkran 35 K



11,7 m - 20,0 m - 22,0 m - 24,0 m - 26,0 m schienenfahrbär / rail-going / mobile
11,7 m - 20,0 m - 22,0 m - 24,0 m - 26,0 m stationär / stationary / stationnaire

Maßstab: 1 : 236
scale / échelle

LIEBHERR

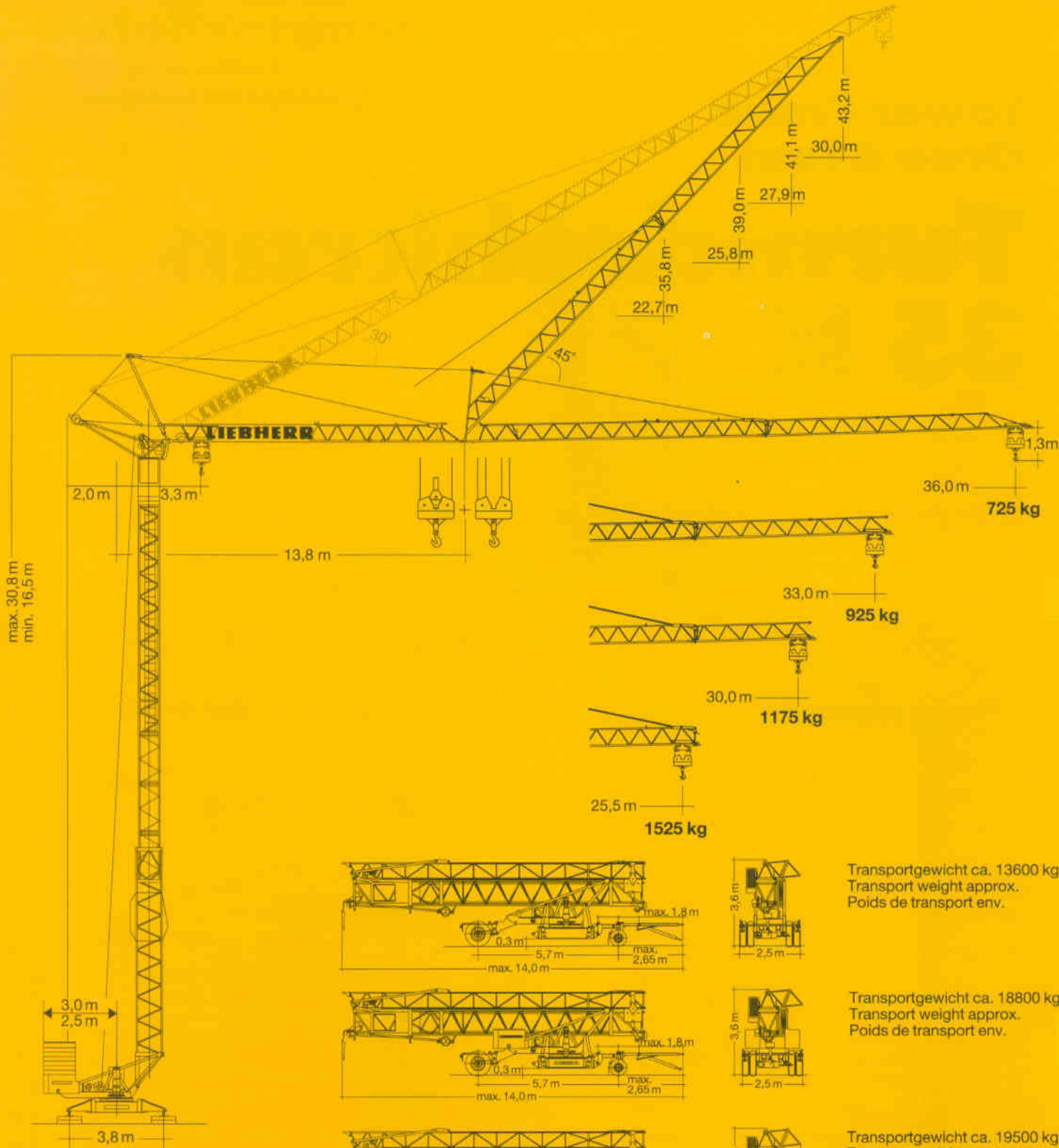

Gewicht Weight Poids

Transportgewicht ca. 13600 kg
Transport weight approx.
Poids de transport env.

Transportgewicht ca. 18800 kg
Transport weight approx.
Poids de transport env.

Transportgewicht ca. 19500 kg
Transport weight approx.
Poids de transport env.

| | | | | |
|--|------------------------|----------------------|--|--|
| Zentralballast Central ballast weight Lest de base | | 1400 kg | Konstruktionsgewicht ca. Dead weight approx. Poids de la construction env. | 10160 kg (bei max. HH 26 m: + 900 kg) |
| Gegengewicht Counterweight Contrepoids | r = 3,0 m r = 2,5 m | 19960 kg 23670 kg | | |

35 K

Ausladung und Tragfähigkeit

Radius and capacity / Portée et charge

| Auslegerlänge Length of jib Longueur de flèche m | max. kg m/kg |  | m/kg | | | | | | | | | | | | | | | | | | | | | |
|---|------------------|---|------|------|------|------|------|------|------|------|------|------|------|------|------|------|------|------|------|------|------|------|------|------|
| | | | 16,0 | 17,0 | 18,0 | 19,0 | 20,0 | 21,0 | 22,0 | 23,0 | 24,0 | 25,0 | 25,5 | 26,0 | 27,0 | 28,0 | 29,0 | 30,0 | 31,0 | 32,0 | 33,0 | 34,0 | 35,0 | 36,0 |
| 36,0 | 3,3-16,7 2075 | | 2075 | 2040 | 1900 | 1780 | 1670 | 1570 | 1490 | 1410 | 1330 | 1270 | 1250 | 1210 | 1150 | 1100 | 1050 | 1010 | 970 | 930 | 890 | 860 | 830 | 800 |
| 33,0 | 3,3-18,2 2075 | | 2075 | 2075 | 2075 | 1970 | 1850 | 1740 | 1650 | 1560 | 1480 | 1410 | 1375 | 1340 | 1280 | 1230 | 1170 | 1130 | 1080 | 1040 | 1000 | | | |
| 30,0 | 3,3-19,7 2075 | | 2075 | 2075 | 2075 | 2075 | 2040 | 1930 | 1820 | 1730 | 1640 | 1560 | 1520 | 1490 | 1420 | 1360 | 1300 | 1250 | | | | | | |
| 25,5 | 3,3-20,5 2075 | | 2075 | 2075 | 2075 | 2075 | 2075 | 2020 | 1910 | 1810 | 1720 | 1640 | 1600 | | | | | | | | | | | |



| m | max. kg m/kg |  | m/kg | | | | | | | | | | | | | | | | | | | | | |
|------|------------------|---|------|------|------|------|------|------|------|------|------|------|------|------|------|------|------|------|------|------|------|------|------|------|
| | | | 10,0 | 11,0 | 12,0 | 13,0 | 14,0 | 16,0 | 18,0 | 20,0 | 22,0 | 24,0 | 25,5 | 26,0 | 27,0 | 28,0 | 29,0 | 30,0 | 31,0 | 32,0 | 33,0 | 34,0 | 35,0 | 36,0 |
| 36,0 | 3,3-9,8 4000 | -16,7 2000 | 3890 | 3430 | 3070 | 2770 | 2520 | 2120 | 1830 | 1600 | 1410 | 1260 | 1175 | 1130 | 1080 | 1030 | 980 | 930 | 890 | 860 | 820 | 790 | 750 | 725 |
| 33,0 | 3,3-10,5 4000 | -18,2 2000 | 4000 | 3790 | 3390 | 3060 | 2790 | 2350 | 2030 | 1780 | 1570 | 1410 | 1300 | 1270 | 1210 | 1150 | 1100 | 1050 | 1010 | 960 | 925 | | | |
| 30,0 | 3,3-11,3 4000 | -19,7 2000 | 4000 | 4000 | 3730 | 3370 | 3070 | 2600 | 2240 | 1970 | 1750 | 1560 | 1450 | 1410 | 1350 | 1280 | 1230 | 1175 | | | | | | |
| 25,5 | 3,3-11,8 4000 | -20,5 2000 | 4000 | 4000 | 3910 | 3540 | 3220 | 2730 | 2360 | 2070 | 1840 | 1650 | 1525 | | | | | | | | | | | |

| m | max. kg m/kg |  | Auslegersteilstellung 30° Elevated jib 30° Flèche inclinée 30° m/kg | | | | | | | | | | | | | | | | | | | | | |
|------|------------------|---|--|------|------|------|------|------|------|------|------|------|------|------|------|------|------|------|------|------|------|--|--|--|
| | | | 14,0 | 15,0 | 16,0 | 17,0 | 18,0 | 19,0 | 20,0 | 21,0 | 22,3 | 23,0 | 24,0 | 25,0 | 26,2 | 27,0 | 28,0 | 28,8 | 30,0 | 31,0 | 31,4 | | | |
| 36,0 | 3,1-14,7 2075 | | 2075 | 2030 | 1875 | 1740 | 1620 | 1510 | 1420 | 1340 | 1240 | 1190 | 1130 | 1070 | 1010 | 970 | 930 | 895 | 850 | 810 | 800 | | | |
| 33,0 | 3,1-16,0 2075 | | 2075 | 2075 | 2075 | 1925 | 1790 | 1680 | 1570 | 1480 | 1380 | 1330 | 1260 | 1190 | 1130 | 1080 | 1040 | 1000 | | | | | | |
| 30,0 | 3,1-17,3 2075 | | 2075 | 2075 | 2075 | 2075 | 1980 | 1850 | 1740 | 1640 | 1520 | 1470 | 1390 | 1320 | 1250 | | | | | | | | | |
| 25,5 | 3,1-18,0 2075 | | 2075 | 2075 | 2075 | 2075 | 2075 | 1940 | 1830 | 1720 | 1600 | | | | | | | | | | | | | |

Geschwindigkeiten

Speeds / Vitesses

| | | |
|---|-----------------------------------|--------------|
|  | U/min 0-1,0 sl./min tr./min | 2,2 kW |
|  | 20,0 / 40,0 m/min | 1,3 / 2,3 kW |
|  | 25,0 m/min | 2 x 2,2 kW |
|  | 0-45° ca. 30 sec. | 4,0 kW |

| Hubwerk Hoist unit Mécanisme de levage | Stufe Step Cran | kg | m/min |
|--|-----------------------|--------------|--------------|
| 11,0 kW  | 1 | 2075 | 6,0 |
| | 2 | 2075 | 25,0 |
| | 3 | 1000 | 50,0 |
| 11,0 kW  | 1 | 2000 4000 | 6,0 3,0 |
| | 2 | 2000 4000 | 25,0 12,5 |
| | 3 | 1000 2000 | 50,0 25,0 |

Leitungsquerschnitt bei 380 V bis 63,0 m 4 x 10 mm²
Cross section of cable up to
Section de câble à jusqu'à

Betriebsspannung 380 V
Operating voltage
Tension de service

Frequenz 50 Hz
Frequency
Fréquence

Gesamtmotorenleistung max. 23,9 kW / 32,0 kVA
Total motor output
Puissance totale des moteurs

Technische Kenngröße nach BGL
Technical nominal size according to the construction machinery list (BGL)
Grandeur caractéristique suivant le barème d'emploi des appareils (BGL)



2108-0035



2108-0035

Technische Daten - Technical data

Caractéristiques techniques

Aufstellvorgang

Erection procedure

Déroulement de montage

Ballasterausladung 5,0 m

Ballasting radius 5,0 m



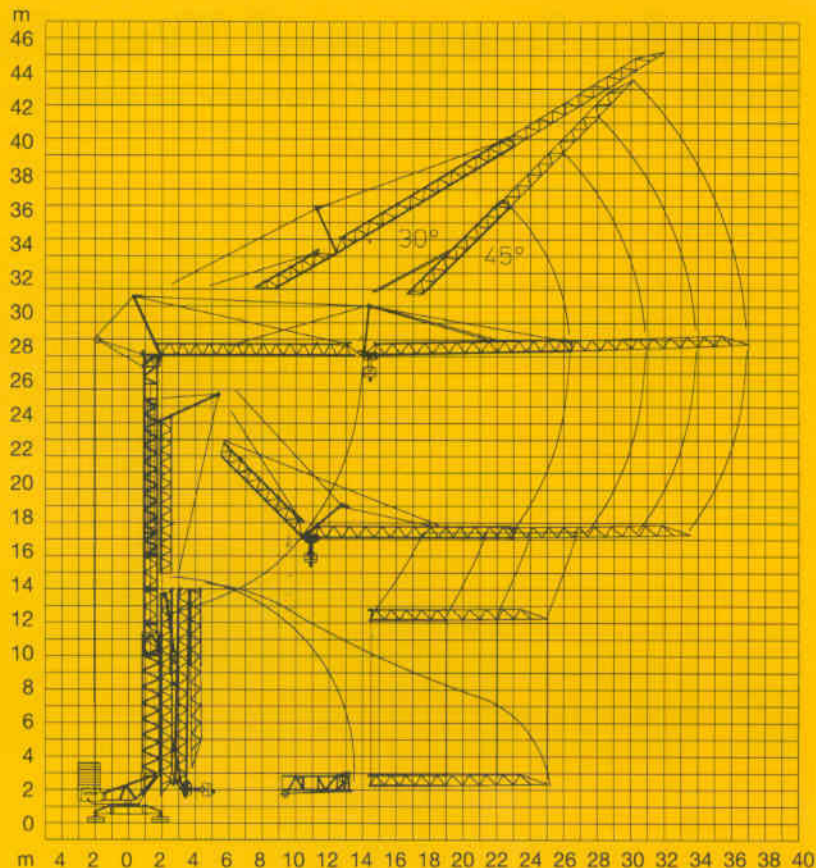











Portée pour dispositif de lestage 5,0 m



Kolli-Liste

Packing List

Liste de colisage

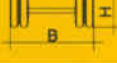
| Pos. Item Rep. | Anz. Qty. Qte | Turmstück Tower section Élément de mât | L (m) | B (m) | H (m) | kg | |
|----------------|---------------|---|---|-------|-------|------|------|
| 1 | 3 |   | 2,10 | 0,85 | 0,88 | 350 | |
| 2 | 1 | Ausleger-Verlängerung 25,5 m – 30,0 m Jib extension Rallonge de la flèche |   | 4,70 | 0,80 | 0,70 | 175 |
| 3 | 1 | Ausleger-Verlängerung 30,0 m – 33,0 m Jib extension Rallonge de la flèche |   | 3,10 | 0,80 | 0,70 | 100 |
| 4 | 1 | Ausleger-Verlängerung 33,0 m – 36,0 m Jib extension Rallonge de la flèche |   | 3,10 | 0,80 | 0,70 | 70 |
| 5 | 1 | Transportachse vorne Tra 50 KW 1 Road transport axle front Essieux de transport avant |   | 3,10 | 1,42 | 0,98 | 465 |
| 6 | 1 | Transportachse vorne Tra 100 KY 1 Road transport axle front Essieux de transport avant |   | 3,00 | 1,13 | 0,97 | 660 |
| 7 | 1 | Transportachse hinten Tra 120 GY 1 Road transport axle behind Essieux de transport arrière |   | 1,90 | 2,50 | 1,05 | 1150 |
| 8 | 1 | Transportachse Tra 200 GZ 3 Road transport axle Essieux de transport |   | 3,10 | 2,50 | 1,10 | 2600 |
| 9 | 1 | Kiste mit Seilen und Kleinteilen Case with ropes and small parts Caisse avec câbles et pièces détachées | 1,00 | 0,80 | 1,00 | 450 | |

Datenblatt Nr. 2870 H 1 B 3 DIN 15018 • BGL 2108-0035 und OENORM T 3 • 10.92

Data sheet

Feuille de caractéristiques

Konstruktionsänderungen vorbehalten!

Subject to alterations!

Sous réserves de modifications!

Printed in Germany

Nehmen Sie Kontakt auf mit
Contact

Mettez-vous en rapport avec

LIEBHERR-WERK BIBERACH GMBH, Postfach 1663, D-7950 Biberach an der Riß 1

Telefon (07351) 41-0, Telex 71 802, Telefax (07351) 4 1225